

NEW ELEVATOR® / TYPICAL CALCULATION

Finite-element modelling for a plot of land 16.82 meters long and 7 meters deep, of which 6.30 m are soft clay and 0.70 m of compacted pozzolana and lapillo. The simulated structure was assumed to be made by a layer of lean mix 12 cm thickness, NEW ELEVATOR® system 95 cm height and a slab 5 cm thickness.

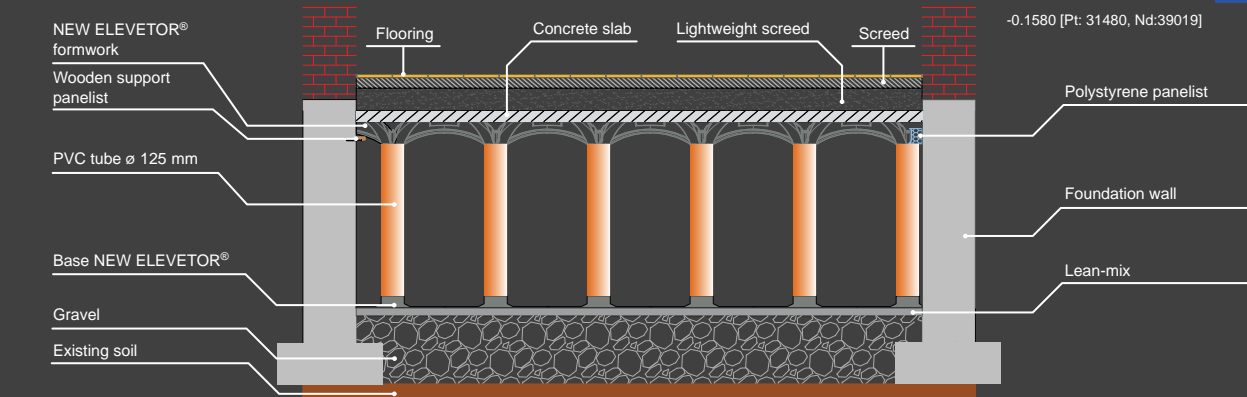
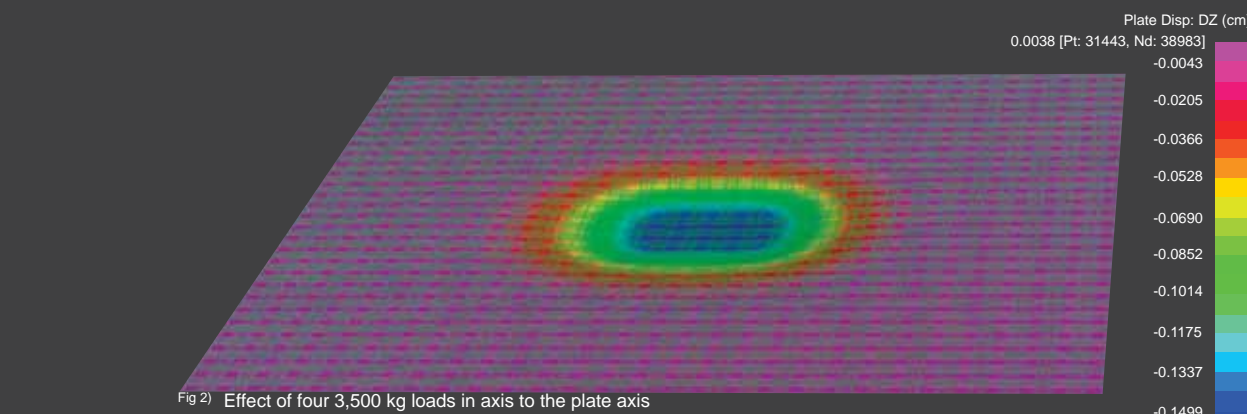
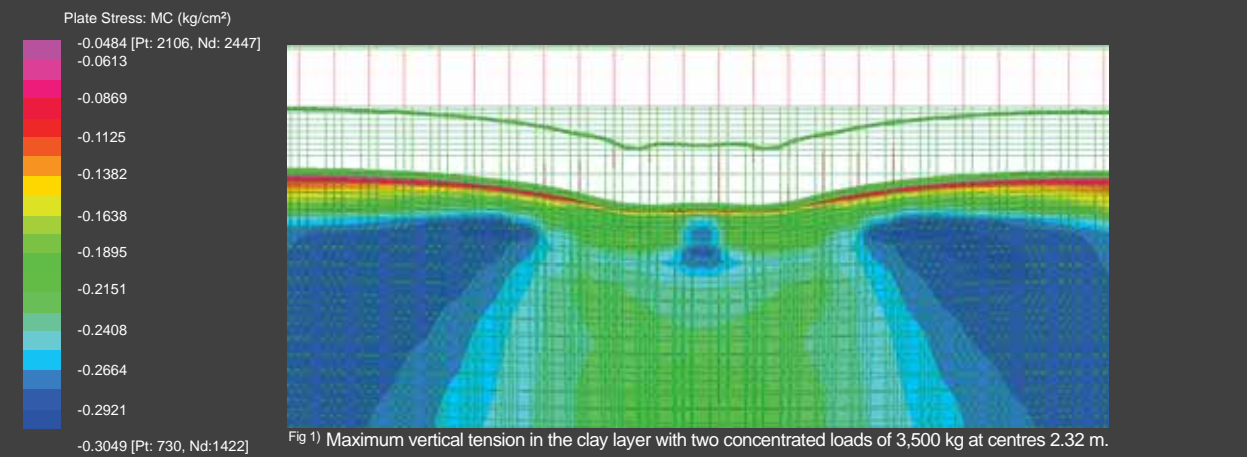

NEW ELEVATOR® / PROJECT COST ANALYSIS

No.	BILL OF MATERIAL	UNIT/MEASURE	QUANTITY	PRICE	TOTAL AMOUNT
1	NEW ELEVATOR® formwork	m²	1		
2	ø 125 mm tube*	No./m²	3		
3	BASE NEW ELEVATOR® footing grid	No./m²	3		
4	Installation of NEW ELEVATOR® system	hours/m²	0.05		
5	Rebar mesh ø 6 20x20 (cost of material and labour)	kg/m²	2.328		
6	Concrete class Rck 250 to fill the tubes (cost of material and labour)	m³/m²			
7	Concrete class Rck 250 to fill the formwork (material and labour)	m³/m²			
8	Concrete class Rck 250 for the floor slab thickness (material and labour)	m³/m²			
Total cost €/m²					

*Supply of the tubes ø 125 mm can be discussed at the time of order.

**Place ø 8 mm reinforcement bars within the tubes that are part of the NEW ELEVATOR® system. These inserts must be joined to the rebar mesh used to reinforce the slab, and should be long enough to reach the base of the tube.

NEW ELEVATOR® H=15 cm DATA

DIMENSION cm	HEIGHT H	CONCRETE QUANTITY to fill the formwork - m³/m²	PALLET HEIGHT m	No. OF UNITS/PALLET	QUANTITY m²
58 X 58	15	0.030	2.5	225	75

The quantity of concrete to fill the pillars is equal to 0.037 m³/m² per meter height.

Concrete consumption calculation:

The concrete consumption for each square meter of ELEVATOR® is:

$$[0,037 \times (\text{NEW ELEVATOR® system height in meters} - 0,15)] + = [\text{m}^3/\text{m}^2] \text{ concrete consumption}$$

Example for an elevation of 2 meters:

Requires: Base NEW ELEVATOR® + PVC tube dia. 125 mm 182.5 cm length + NEW ELEVATOR® H 15
Concrete consumption = $(0.037 \times 1.85) + 0.030 = 0.098 \text{ m}^3/\text{m}^2$

NEW ELEVATOR® TANK SYSTEM

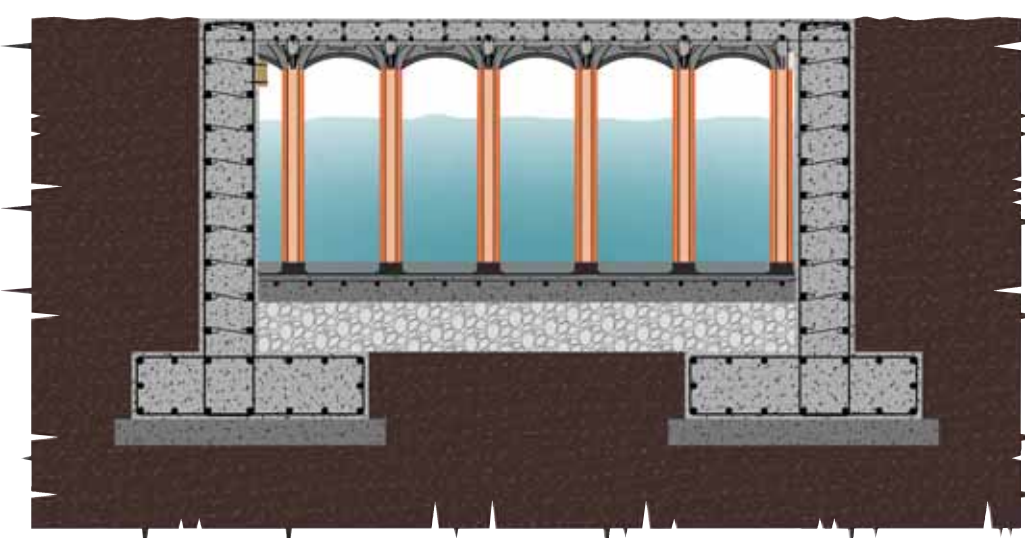

Stormwater management systems for both residential and industrial use can be made using NEW ELEVATOR®. Tanks can be built for temporary stormwater storage and attenuation, or permanent storage and reuse. The NEW ELEVATOR® system allows to build tanks of any shape and up to 2 meters depth without using cranes or heavy-lifting equipment.

Disclaimer: the values shown in this brochure are for guidance only. They are not meant to be used for design criteria. Their use and reliance thereon for any purpose by anyone is entirely voluntary and at the sole risk of the user. GEOPLAST is not responsible for any loss, claim, or damage resulting from their use.

LOAD TABLE for NEW ELEVATOR® H=120 cm

TYPE OF LOAD	Overload kg/m²	Min. slab thickness cm	Lean mix cm	Pressure on the scree kg/cm²	Screed thickness cm	Pressure on the soil kg/cm²	Rebar diameter mm	Rebar mesh cm x cm
RESIDENTIAL	1,000	4	0		0	3.44	6	20 x 20
			5		0	1.49		
			10		0	0.82		
			5	1.49	10	0.52		
	1,800	5	0		0	5.68	6	20 x 20
			5		0	2.45		
INDUSTRIAL	5,000	7	10	3.48	25	0.67	6	20 x 20
	10,000	10	15	4.30	30	0.87	8	20 x 20



NEW ELEVATOR®



The formwork for ventilated foundations from 70 cm to 250 cm



edilizia
building

www.geoplast.it

Authorized dealer:



Manufactured by:
GEOPLAST S.p.A.
Via Martiri della Libertà, 6/8
35010 Grantorto (PD) - Italy
tel +39 049 9490289 - fax +39 049 9494028
e-mail: geoplast@geoplast.it - www.geoplast.it

REV. 004
ST. 11/2011

NEW ELEVATOR® / USE AND CHARACTERISTICS

- Create ventilated foundations of any height
- The formwork is treadable before pouring
- High load-bearing capacity
- It can be laid on the subgrade without lean mix



NEW ELEVATOR® / USE AND CHARACTERISTICS



NEW ELEVATOR® / HOW TO INSTALL

- Installation surface: cover the subgrade with lean mix to create an even surface for **NEW ELEVATOR®**. Lean mix thickness to spec;
- Installation: place the **NEW ELEVATOR®** system made by **GEOPLAST S.p.A.**, made by polypropylene formwork size **58 x 58 x h15 cm**, joined with tubes \varnothing 125 mm of length as by project specification, with **BASE NEW ELEVATOR®** footing grid (**58 x 58 x h2.5 cm**): it is recommended to place the parts from right to left and from top to bottom.
 1. Lay the **BASE NEW ELEVATOR®** footing grid (**58 x 58 x h2.5 cm**): it is recommended to place the parts from right to left and from top to bottom.
 2. Fit tubes into each cup of the footing grid. The tubes are cut to the length suitable to achieve the specified height of **NEW ELEVATOR®** (from 70 to 200 cm).
 3. Place the **NEW ELEVATOR®** FORMWORK (**58 x 58 x h15**): the operation is performed attaching the parts to the tubes from the right-hand side to the left, and from top to bottom, always keeping the printed arrow upwards.
 4. The Grid + Tube + Formwork assembly guarantees a perfect perpendicularity of the pillars within the foundation.
 5. Place the specified rebar mesh over the surface of the **NEW ELEVATOR®** system (ref. to load table).
 6. Place \varnothing 8 mm reinforcement bars within the tubes that are part of the **NEW ELEVATOR®** system. These inserts must be joined to the rebar mesh used to reinforce the slab, and should be long enough to reach the base of the tube.
 7. Slab pour: use a Rck 250 kg/cm² concrete to fill the tubes and the formwork, cover the rebar mesh and reach the designed slab thickness.

BASE NEW ELEVATOR® / ADVANTAGES AND CHARACTERISTICS

BASE NEW ELEVATOR® IS AN ELEMENT IN RECYCLED POLYPROPYLENE (*) THAT GUARANTEES AN EASY AND QUICK INSTALLATION OF THE PVC TUBES SUPPORTING THE ELEVATOR SYSTEM. INSTALLATION IS PRECISE AND TUBES REMAIN PERFECTLY VERTICAL.

QUICK AND EASY SYSTEM

(*)Recycled Polypropylene: Flexural modulus 1,100 N/mm² - Tensile strength 35 N/mm² - Coefficient of thermal expansion 0.15 mm/m/°C

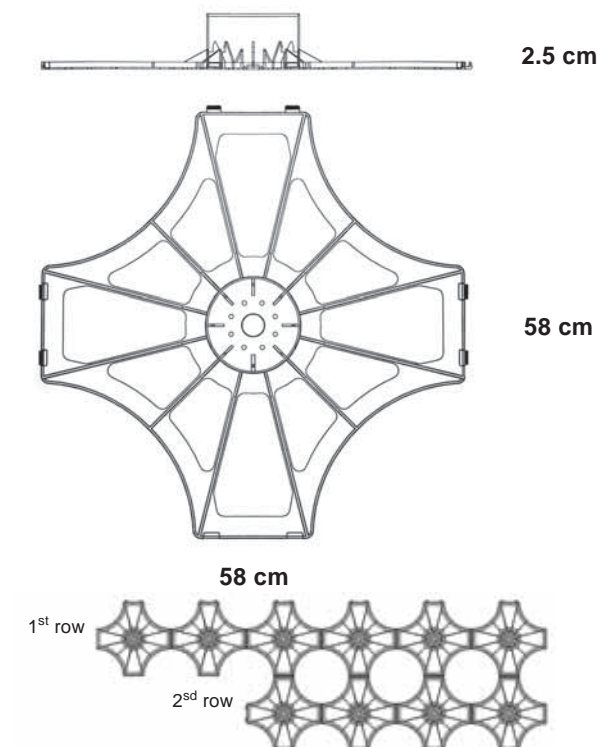

2

NEW ELEVATOR® FORMWORK / ADVANTAGES AND CHARACTERISTICS

NEW ELEVATOR® IS AN INNOVATIVE SYSTEM WITH DIMENSIONS **58X58 H15 CM** THAT CREATES A CRAWL SPACE AND ALLOW INSTALLATIONS UNDERNEATH REDUCING CONSIDERABLY CONCRETE CONSUMPTION AND INSTALLATION TIME. THE CONCRETE CONSUMPTION FLUSH WITH THE TOP LAYER IS 0.030 m³/m², WHILE THE AMOUNT OF CONCRETE NECESSARY TO FILL THE PILLARS IS 0.037 m³/m² PER LINEAR METER OF HEIGHT.

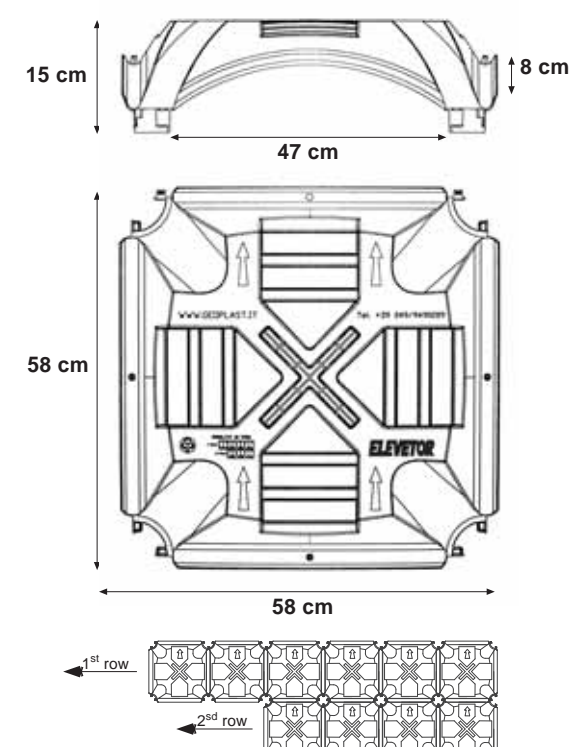

3

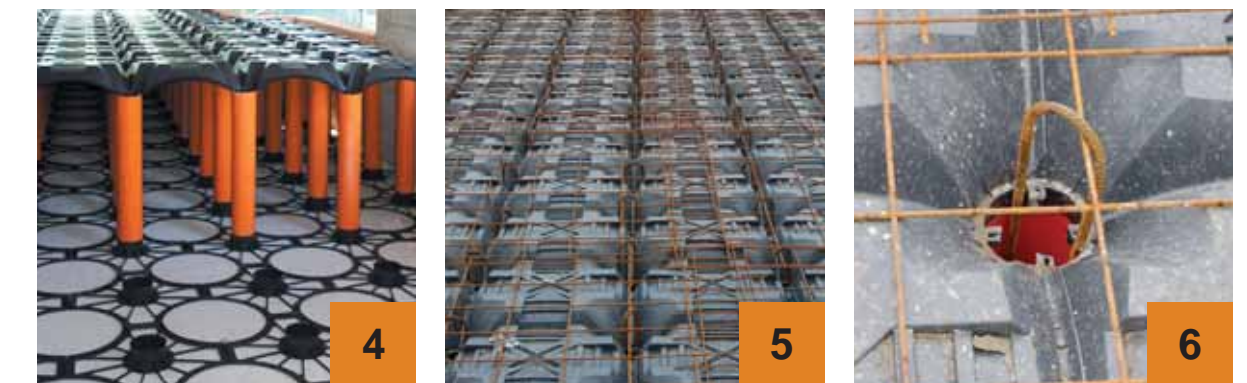

4